

SATURN 650

Pendant direct or direct/indirect LED luminaire.

Mounting:	Suspended on 1,5m long steel wire suspension (with wire length control)
Body material:	Steel and aluminium
Colour:	Standard White RAL 9016, other RAL colours on request (please add RAL colour after index number)
LED module:	Signify (Philips), Osram, Tridonic or equivalent LED module included
Colour temperature:	3000/4000K, other on request
Colour Rendering Index (CRI):	>80 in standard, other on request
Driver:	EVG/DALI on request
Emergency unit:	On request - Standard or DALI 3 hour emergency unit
Movement sensor:	on request
Daylight control sensor:	on request
Operating temperature range:	0°C ... +40°C
IP Class:	IP20 in standard, IP44 on request
Power:	220-240V 50/60Hz
Lighting direction:	Direct lighting or direct/indirect lighting
Light distribution:	Symmetric
Diffuser:	OP (Opal)
General data:	5 Years standard warranty

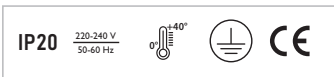
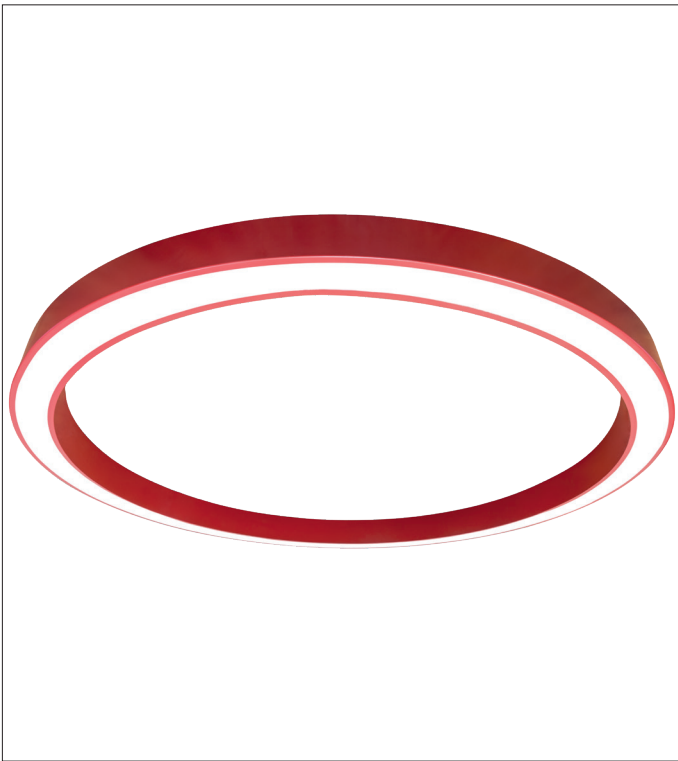

Drawing

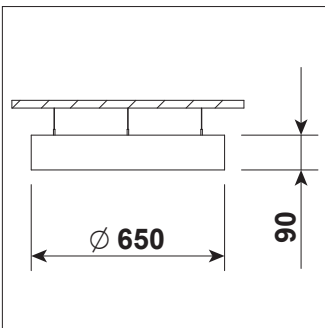

Energy saving MasterConnect wireless lighting control system with daylight and movement detection technology on request.



Different lumen output or wattage available on request

All other technical features such as: Luminaire Efficacy, LOR, Lumen maintenance L/B etc. available in our pricelist

Wattage of products may vary due to constant LED efficacy improvements. Luminous flux & Luminaire Power tolerance +/- 10%.

System power consumption (LED module & driver) depends on components used

Efficacy depends on type of LED's, electronics, optics and diffusor and may differ from shown in our data pages. Most up to date information can be found in our lighting data file database.

Available versions

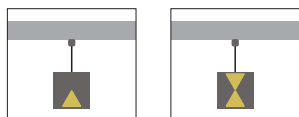

SATURN 650

Product code	Product name	Gross Lumen [lm]	Nett Lumen [lm]	Power [W]	Efficacy [lm/W]	Colour temperature [K]	Diameter [mm]	Height [mm]	Nett Weight [kg]
Suspended, light down (suspension set and power cable with ceiling cup included)									
50.00010.83.E.OP	SATURN 650/6600lm/830/E/OP	6600	3630	40	91	3000	Ø 650	90	6,5
50.00010.84.E.OP	SATURN 650/6600lm/840/E/OP	6600	3630	40	91	4000	Ø 650	90	6,5
Suspended, light up/down, reflected light only (suspension set and power cable with ceiling cup included)									
50.00020.83.E.OP	SATURN 650 UP_DN/6600lm/830/E/OP	6600	3630	40	91	3000	Ø 650	90	6,5
50.00020.84.E.OP	SATURN 650 UP_DN/6600lm/840/E/OP	6600	3630	40	91	4000	Ø 650	90	6,5

Pendant with direct light

Pendant with direct/indirect light

