

DLK 100 DQ



Square recessed downlight. Top quality COB LED module with colour consistency MacAdams ≤ 3 , extensive portfolio of lumen ranges, CCTs and spectra. Variety of drivers: standard EVG on/off, DALI and wireless controlled as MasterConnect or Casambi on request. Remote, wireless occupancy & daylight sensor available to allow significant energy savings and wireless connectivity. Mounting without tools into any type of suspended ceiling. Body is made of aluminium and steel. Standard colour RAL 9003M any other colour from basic RAL range available at no extra cost. Selection of beam angles, lumen outputs and drivers allows to use this luminaire in different types of lighting projects.

Luminous flux & Luminaire Power tolerance up to 10%. System power consumption depends on components used. Luminous efficacy depends on type of LED's, electronics, optics and diffusor. The most up to date technical parameters can be found on our website and in database of LDT files.

Lighting direction:



PDF datasheet:



DLK 100 DQ

Mounting:	Recessed mounting
Body material:	Steel and aluminium
Colour:	Standard white RAL 9003M, other RAL colours on request
Lumen output:	Standard up to 3000 lm, any other on request
LED module:	Signify (Philips), Tridonic or equivalent COB LED module
Colour temperature:	2700/3000/4000K/2700-6500K TW, other on request
Colour Rendering:	CRI>80 in standard, other on request
Driver:	EVG on-off/DALI/MC (MasterConnect)/Casambi, other on request
Wireless control:	Philips MasterConnect / Casambi, other on request
Daylight/Occupancy sensor:	Wireless MCS sensor
Emergency unit:	N/A
Operating temperature range:	0°C ... +35°C
IP Class:	IP44/20 in standard
Power:	220-240V 50/60Hz
Lighting direction:	Direct
Light distribution:	Symmetric
Optics:	Reflector
Beam angle:	16°, 24°, 36°, 54°
Diffusor:	CG clear glass
Warranty:	5 Years standard warranty

DLK 100 DQ recessed mounted, light down

All current index numbers, lumen outputs, power consumption and many other technical information are available in our 2024 pricelist. Details on wireless lighting control systems on page number 896.



Energy saving MasterConnect wireless lighting control system with daylight and movement detection technology on request.



MCS wireless daylight&occ sensor



XCS wireless switch

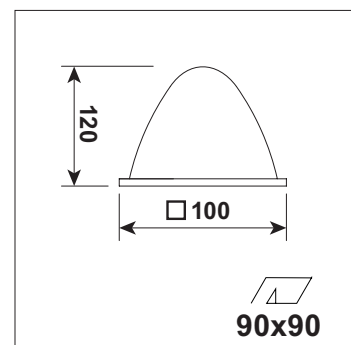

Basic dimensions